

ARCHITECTURAL PANELS INSTALLATION INSTRUCTIONS

PANEL INFORMATION AND TRIM DETAILS

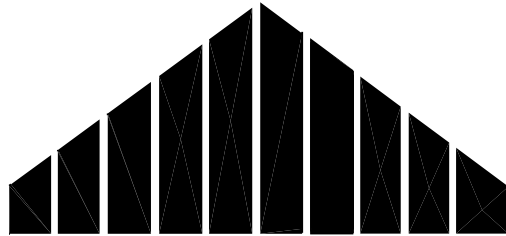

CMS

COASTAL METAL SERVICE

DIVISION OF BEACON SALES

STYLE "A" EAVE TRIM

1- THE STYLE "A" EAVE TRIM IS HELD IN PLACE BY A PAN HEAD SCREW

2- THE PANEL MUST BE 1 INCH LONGER THAN THE MEASURED ROOF. THE PANEL MUST BE FIELD NOTCHED 3/4 OF AN INCH AND FOLDED BACK 180 DEGREES UNDER THE 1" EXTENSION

3- WHEN PANELS ARE INSTALLED OVER A SOLID DECK, A WATER PROOF BARRIER MUST BE USED

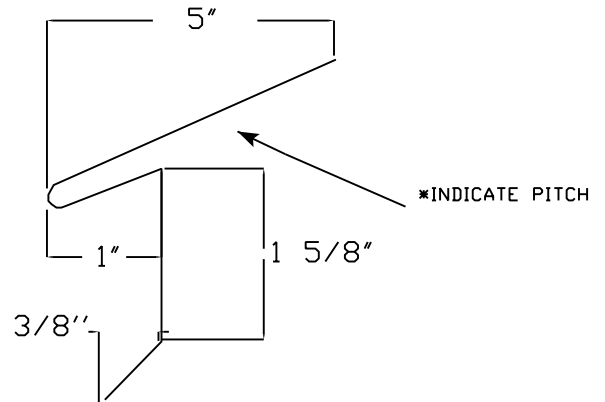

STYLE "A" EAVE TRIM
CLOSED HEM

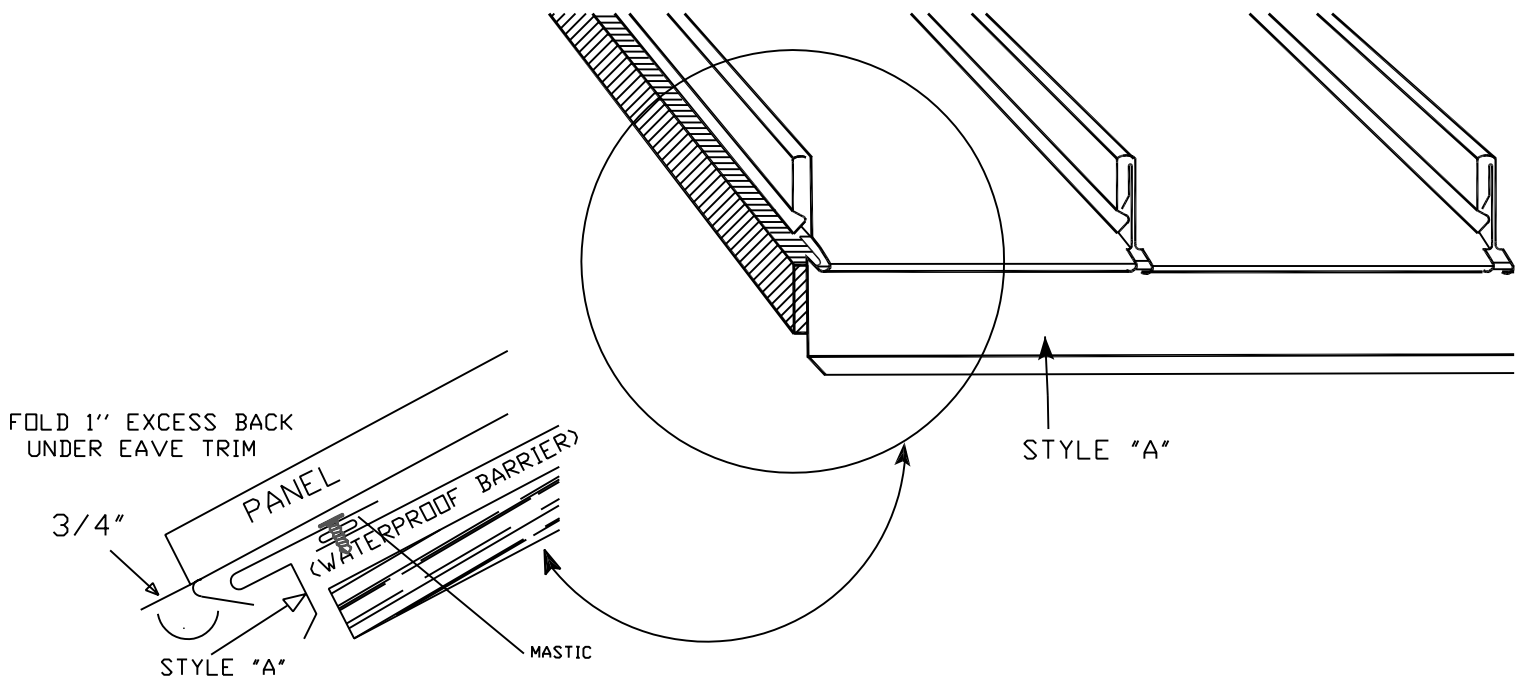

COASTAL METAL SERVICE

DIVISION OF BEACON SALES

1120 WEST CHESTNUT STREET
BROCKTON, MA 02301

PHONE: 1-866-792-8872

1-508-580-8436

FAX: 1-508-580-9704

HIP AND RIDGE

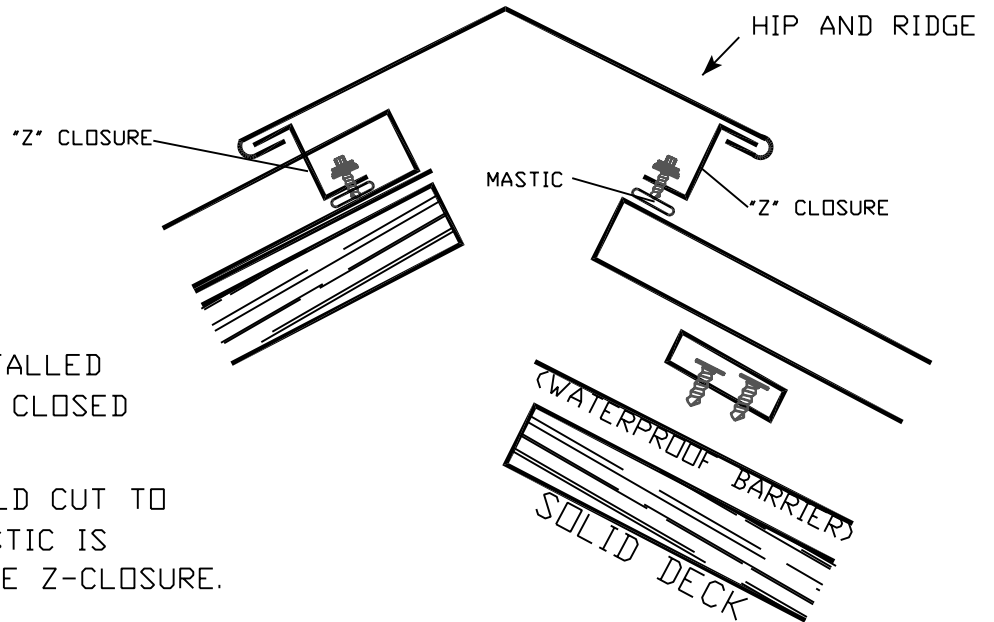

1- THE HIP & RIDGE IS INSTALLED OVER THE "Z" CLOSURE AND CLOSED IN THE FIELD.

2- THE "Z" CLOSURE IS FIELD CUT TO FIT INSIDE THE PANEL. MASTIC IS USED ON THE BOTTOM OF THE Z-CLOSURE.

3- A WASHER SCREW IS USED TO HOLD THE "Z" CLOSURE IN PLACE ON 4 INCH CENTERS

4- THE PANEL IS HELD IN PLACE BY CLIPS THE CLIPS ARE HELD IN PLACE BY 2 PAN HEAD SCREWS

HIP AND RIDGE
W/ OPEN HEMS

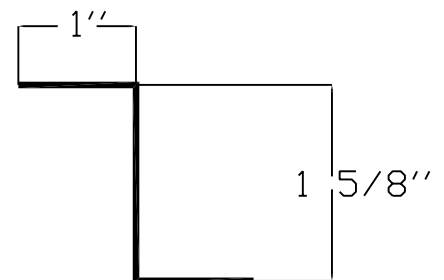
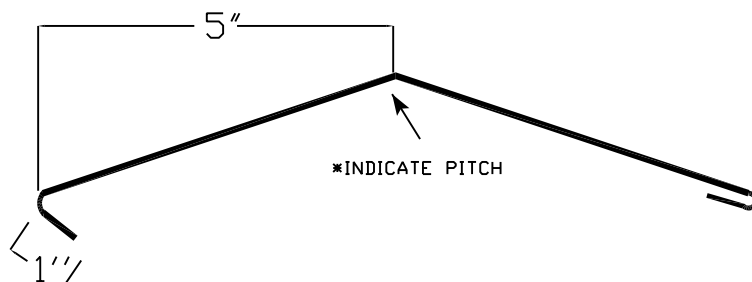

"Z" CLOSURE



COASTAL METAL SERVICE
DIVISION OF BEACON SALES

1120 WEST CHESTNUT STREET
BROCKTON, MA 02301
PHONE: 1-866-792-8872
1-508-580-8436
FAX: 1-508-580-9704

VENTED RIDGE CAP

7" OF FREE AIR SPACE PER LINEAR FOOT OF RIDGE

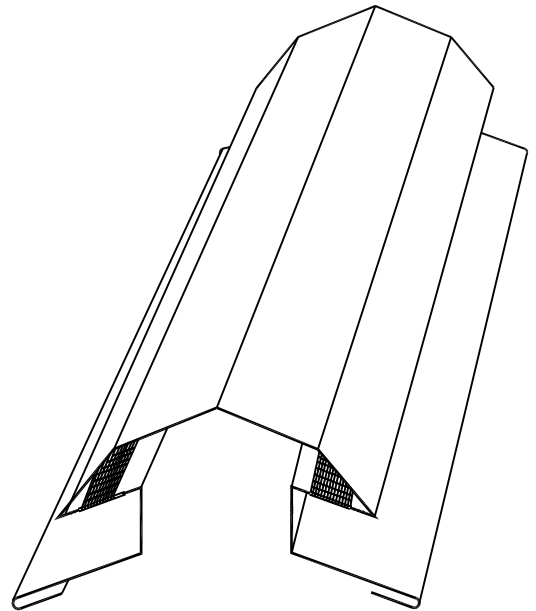
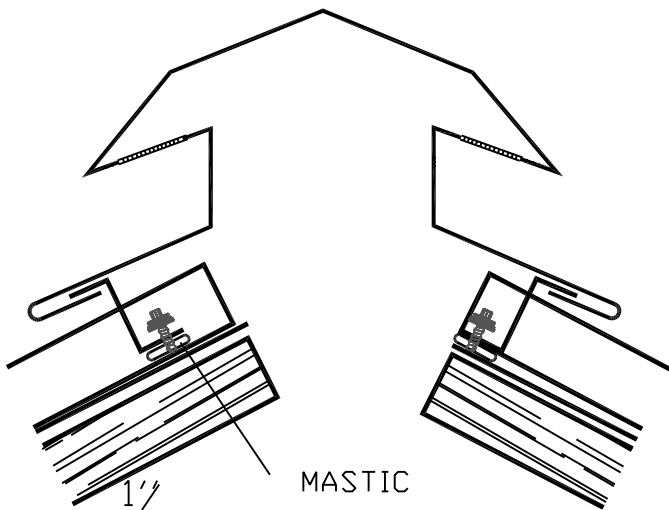
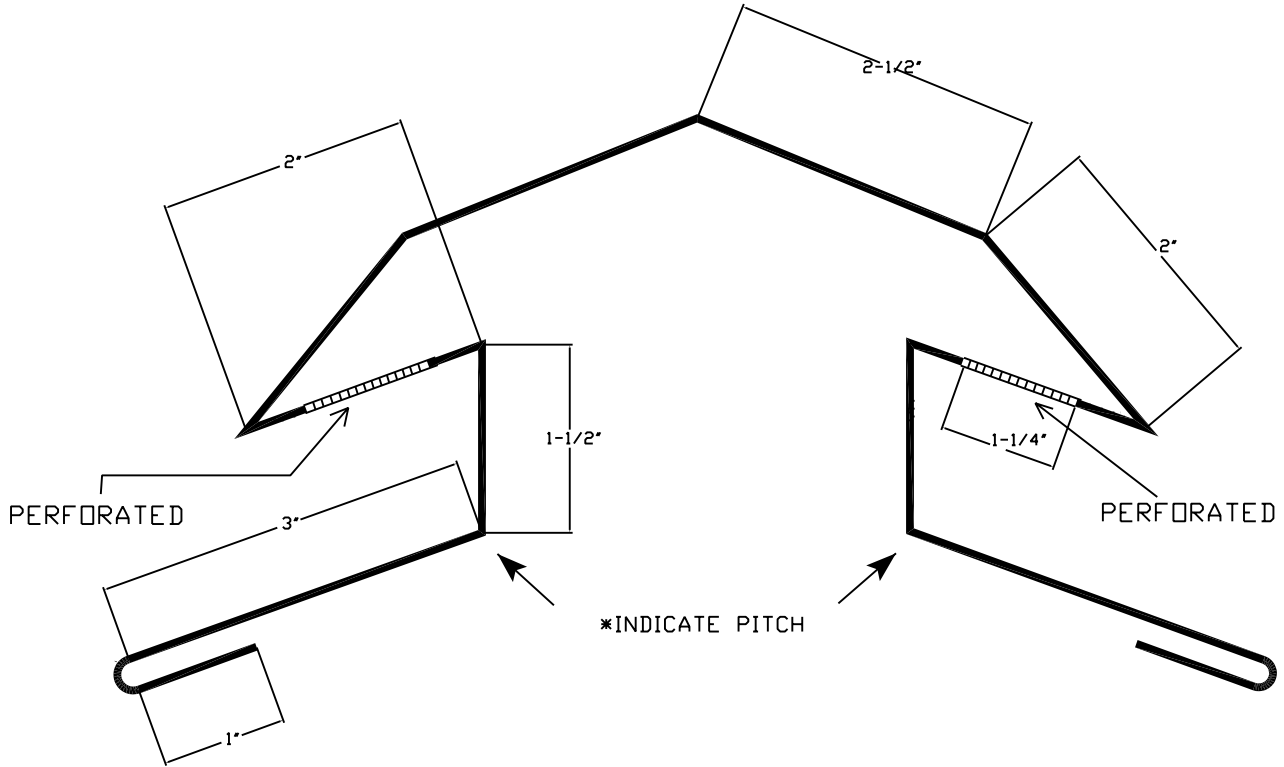

COASTAL METAL SERVICE
DIVISION OF BEACON SALES

1120 WEST CHESTNUT STREET
BROCKTON, MA 02301
PHONE: 1-866-792-8872
1-508-580-8436
FAX: 1-508-580-9704

RAKE TRIM

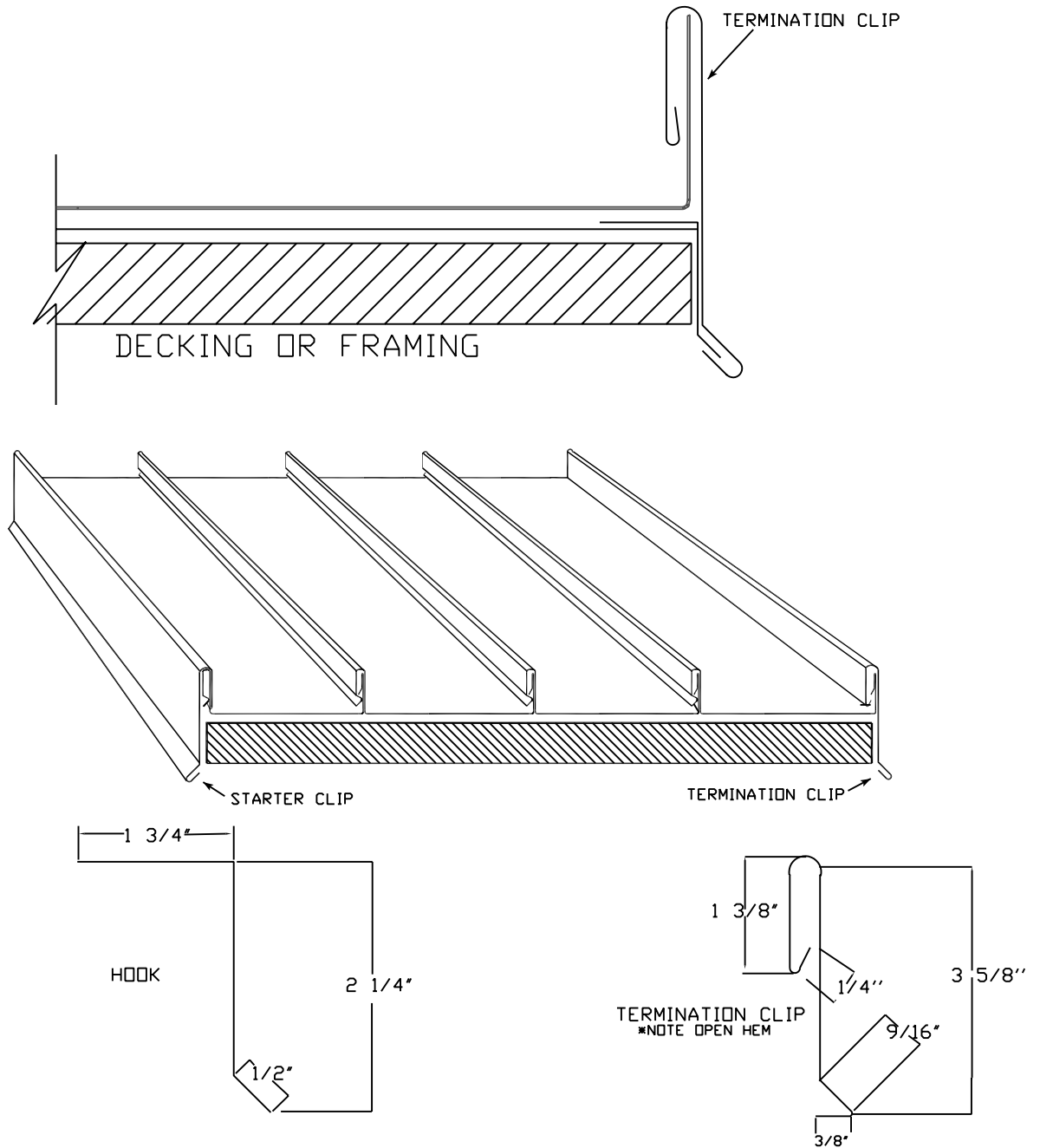

COASTAL METAL SERVICE

DIVISION OF BEACON SALES

1120 WEST CHESTNUT STREET
BROCKTON, MA 02301

PHONE: 1-866-792-8872

1-508-580-8436

FAX: 1-508-580-9704

SIDEWALL

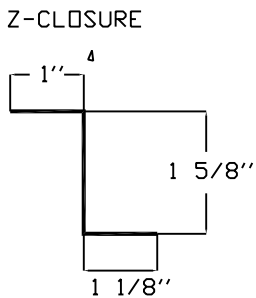
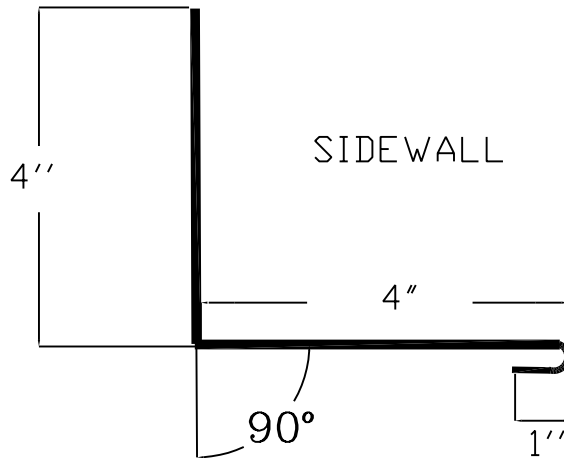
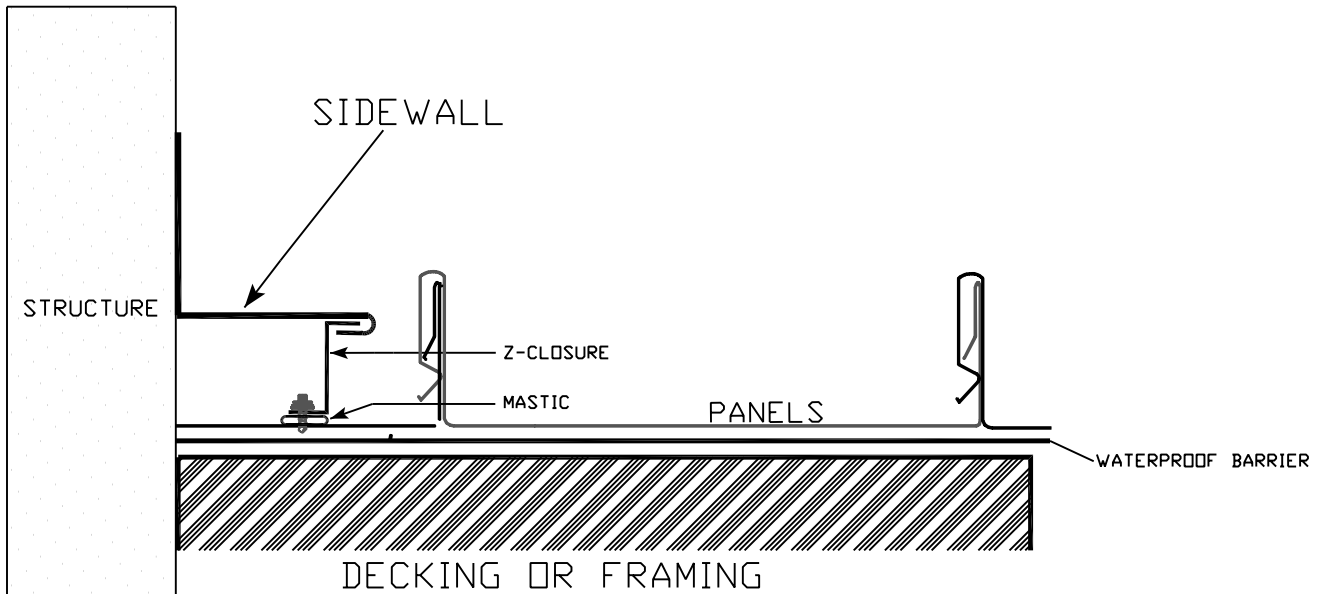

COASTAL METAL SERVICE DIVISION OF BEACON SALES

1120 WEST CHESTNUT STREET
BROCKTON, MA 02301
PHONE: 1-866-792-8872
1-508-580-8436
FAX: 1-508-580-9704

HEADWALL

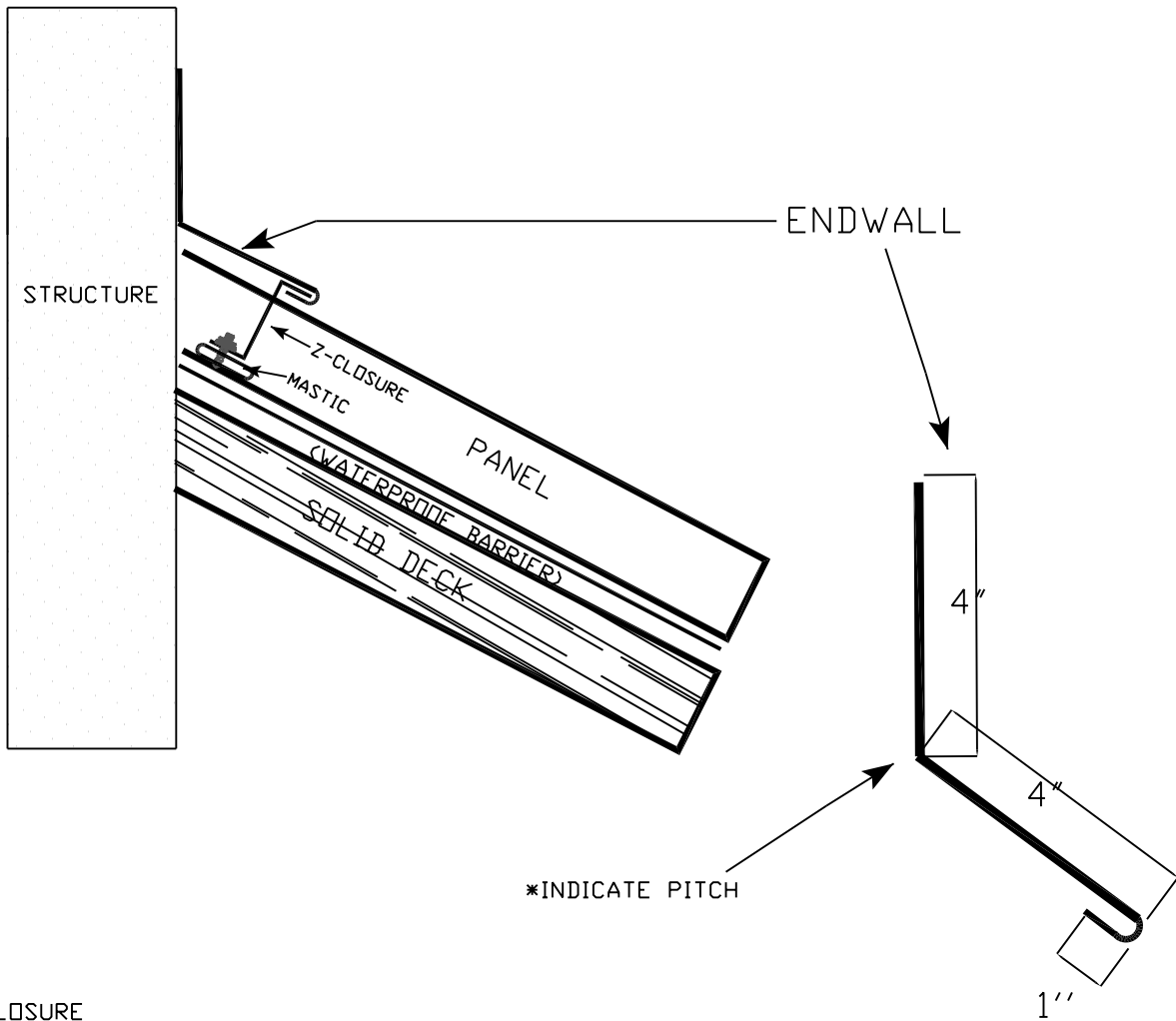

Z-CLOSURE

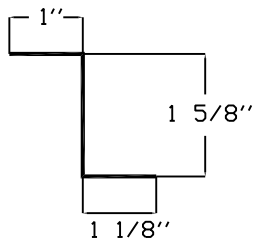

COASTAL METAL SERVICE DIVISION OF BEACON SALES

1120 WEST CHESTNUT STREET
BROCKTON, MA 02301
PHONE: 1-866-792-8872
1-508-580-8436
FAX: 1-508-580-9704

VALLEY

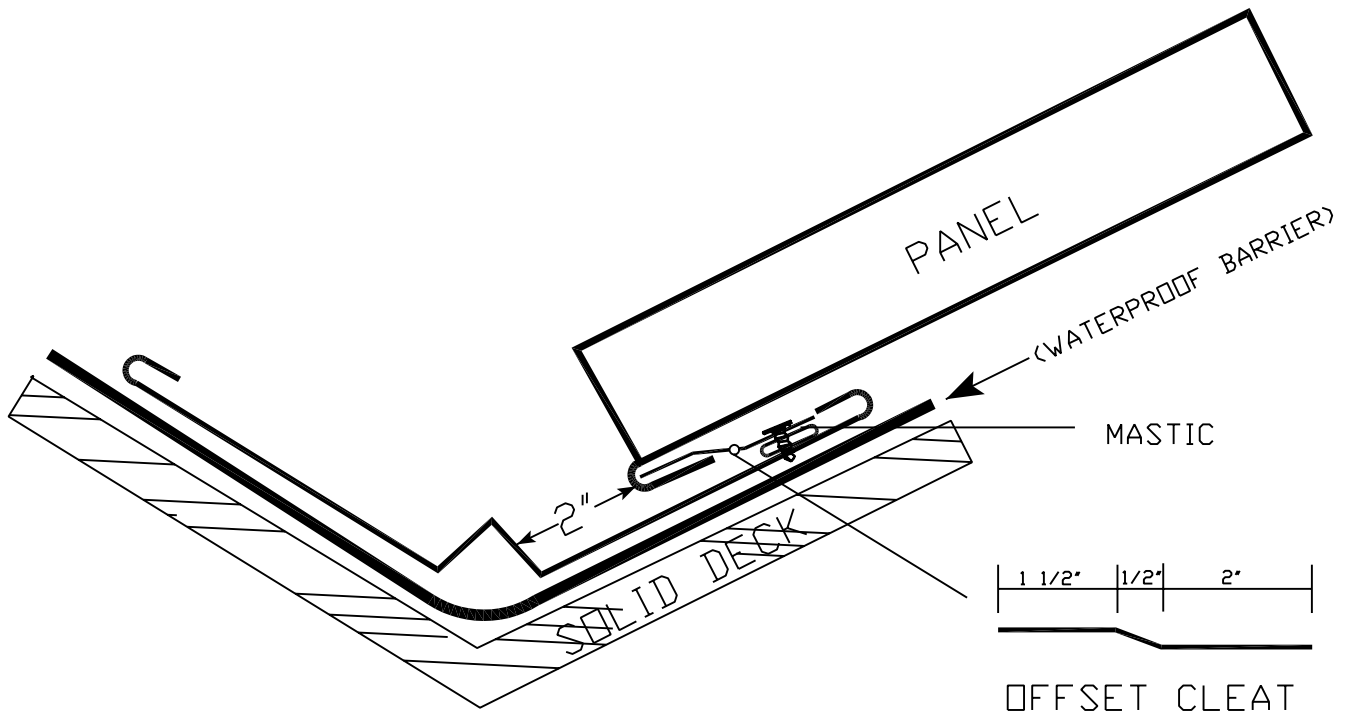
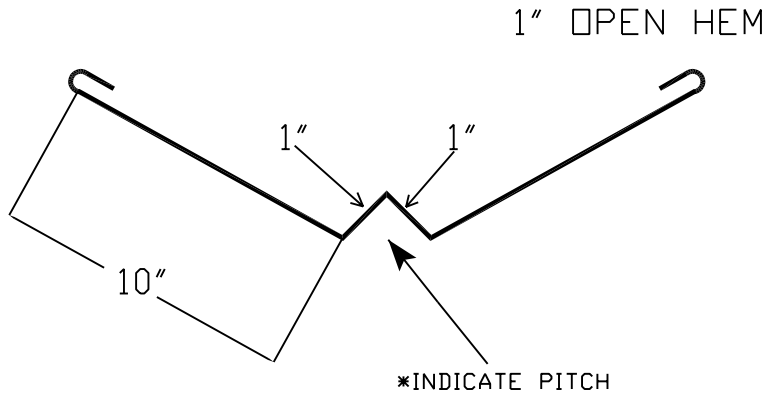

COASTAL METAL SERVICE

DIVISION OF BEACON SALES

1120 WEST CHESTNUT STREET
BROCKTON, MA 02301

PHONE: 1-866-792-8872

1-508-580-8436

FAX: 1-508-580-9704



TRANSITION TRIM

TRANSITION TRIM IS INSTALLED UNDER THE HIGHER ROOF AND OVER THE TOP OF THE LOWER ROOF AND ATTACHES TO THE "Z" CLOSURE.

ONCE THE TRANSITION TRIM IS IN PLACE, A "J"-CLEAT IS INSTALLED TO SECURE THE END OF THE HIGHER PITCH ROOF PANEL.

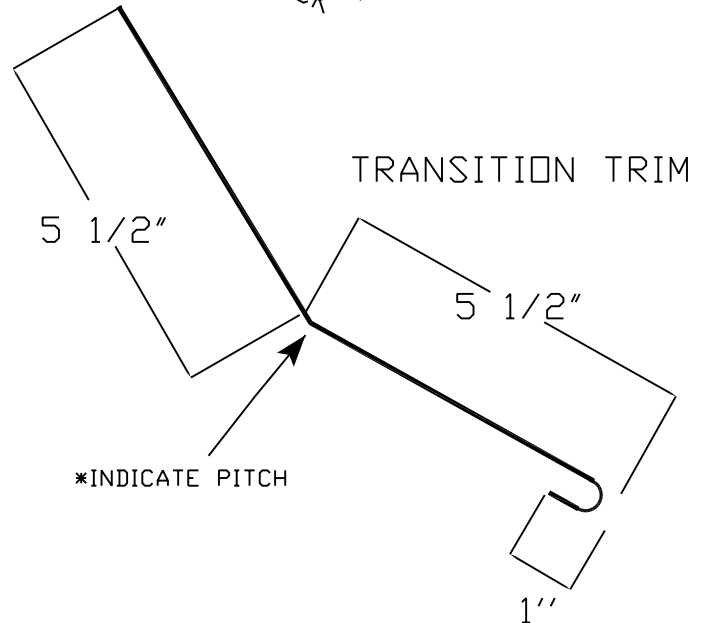
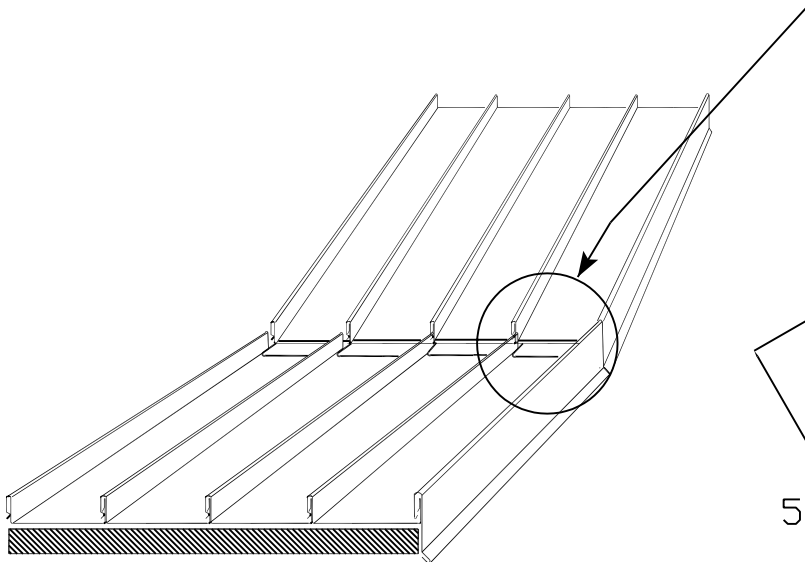
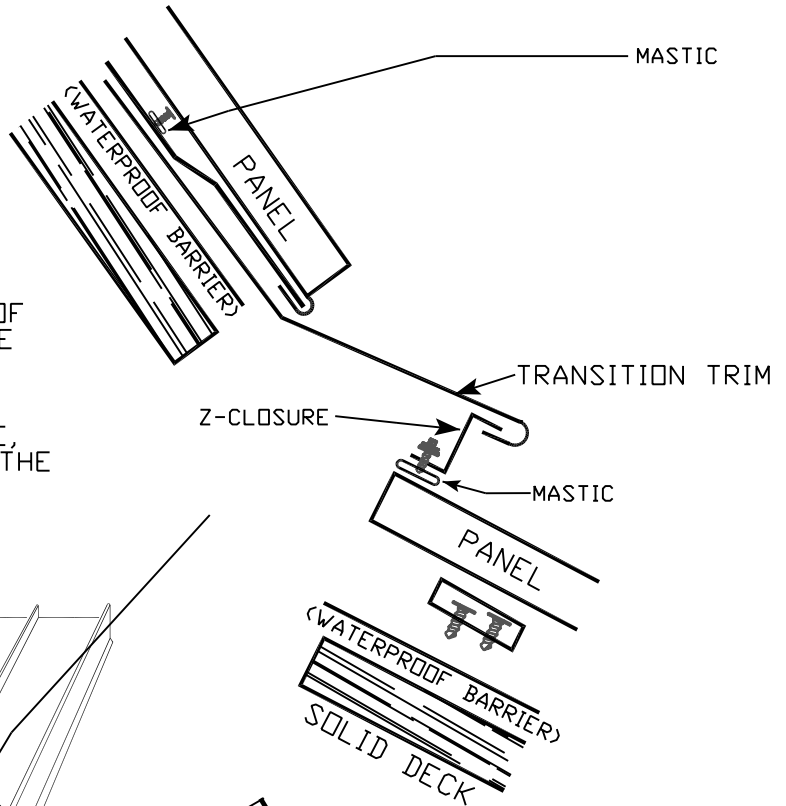

Z-CLOSURE

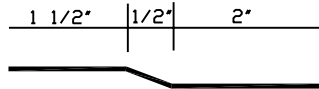
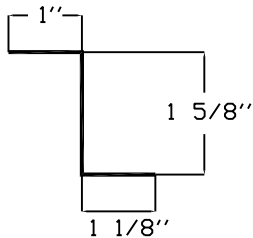

OFFSET CLEAT



COASTAL METAL SERVICE
DIVISION OF BEACON SALES

1120 WEST CHESTNUT STREET
BROCKTON, MA 02301
PHONE: 1-866-792-8872
1-508-580-8436
FAX: 1-508-580-9704

COPING CAP

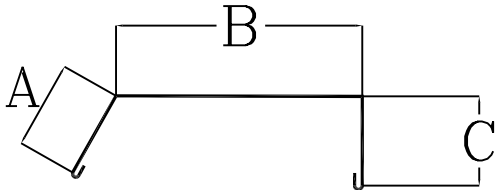
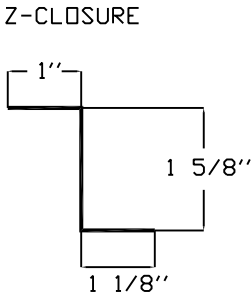
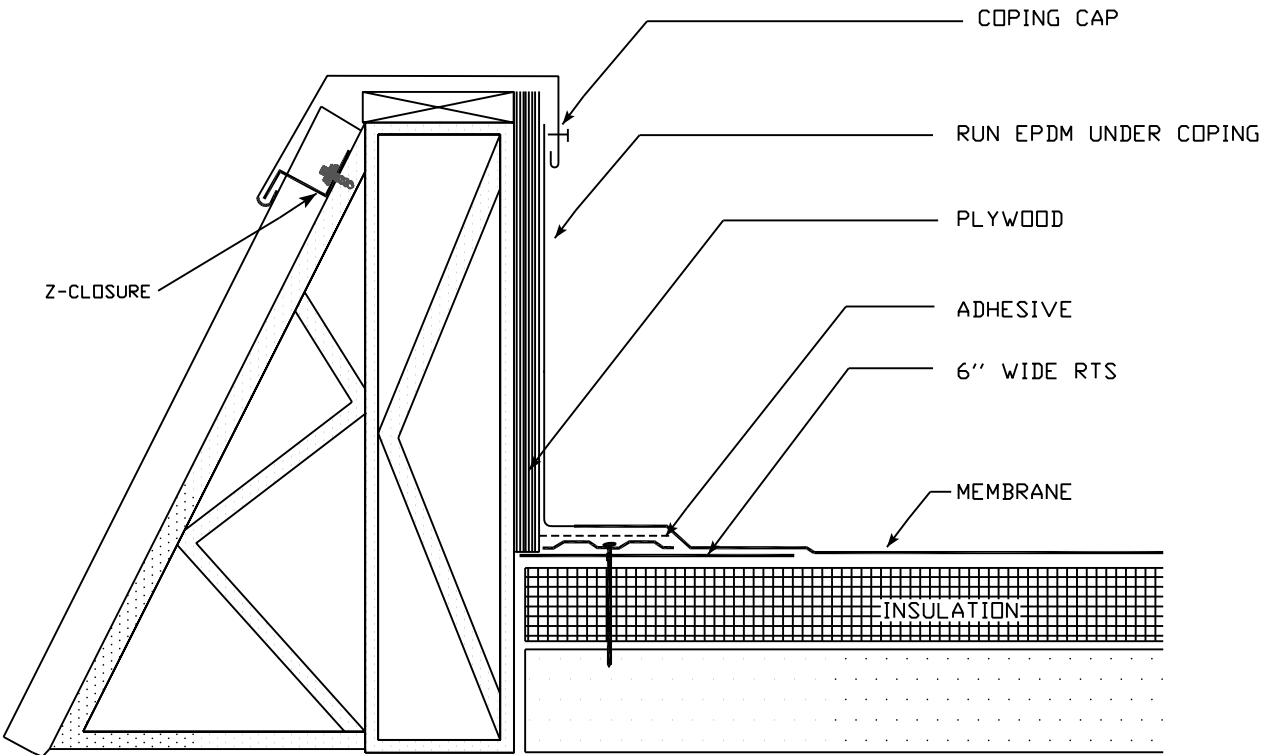

PLEASE PROVIDE DIMENSIONS



COASTAL METAL SERVICE DIVISION OF BEACON SALES

1120 WEST CHESTNUT STREET
BROCKTON, MA 02301

PHONE: 1-866-792-8872

1-508-580-8436

FAX: 1-508-580-9704

SOFFIT AND PERFORATED SOFFIT

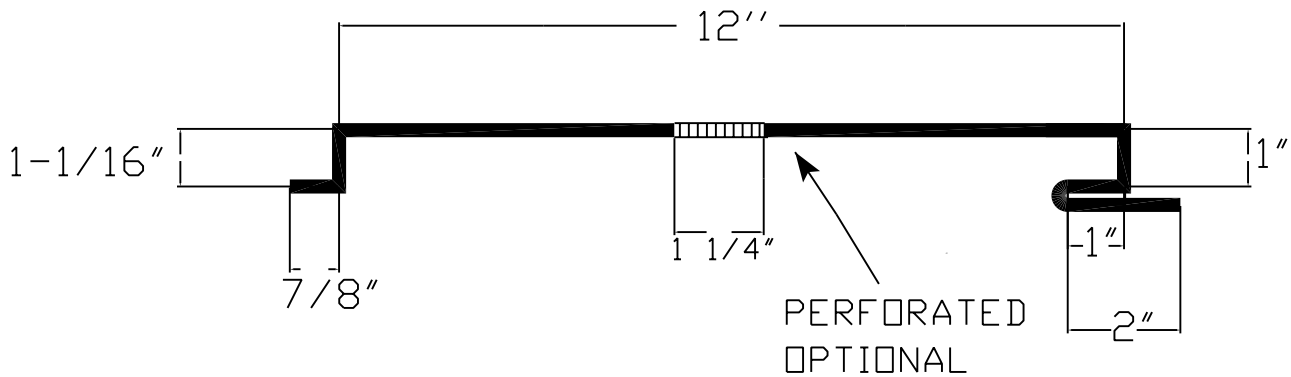
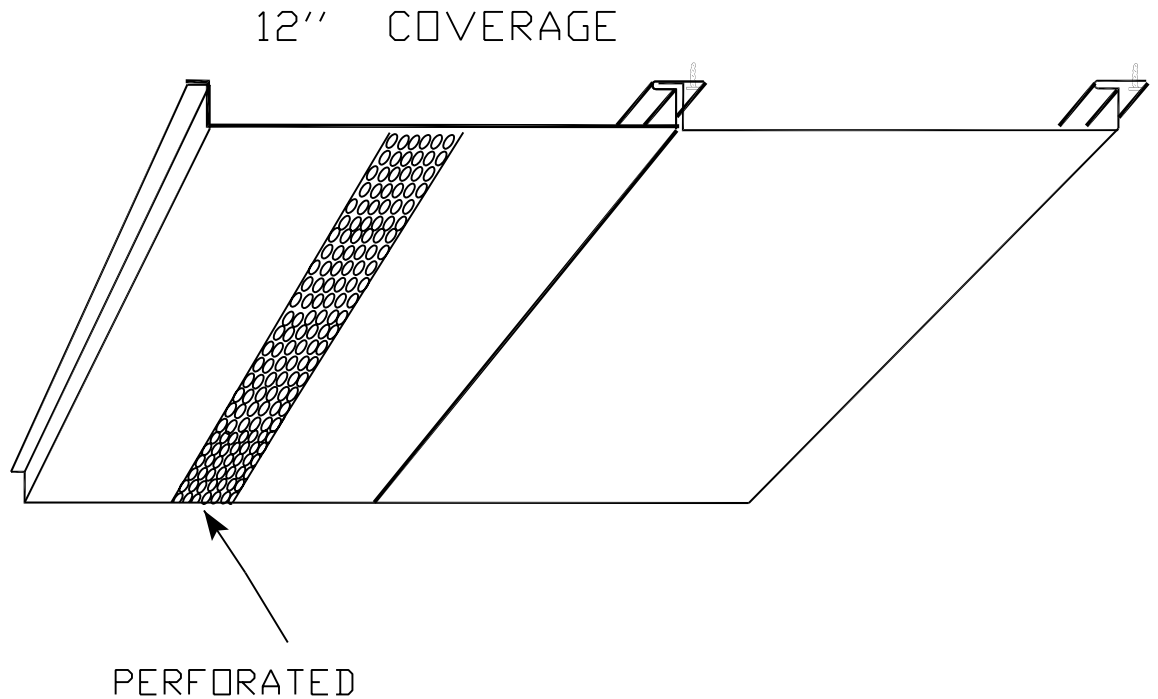

COASTAL METAL SERVICE DIVISION OF BEACON SALES

1120 WEST CHESTNUT STREET
BROCKTON, MA 02301
PHONE: 1-866-792-8872
1-508-580-8436
FAX: 1-508-580-9704

VERTICAL WALL PANEL

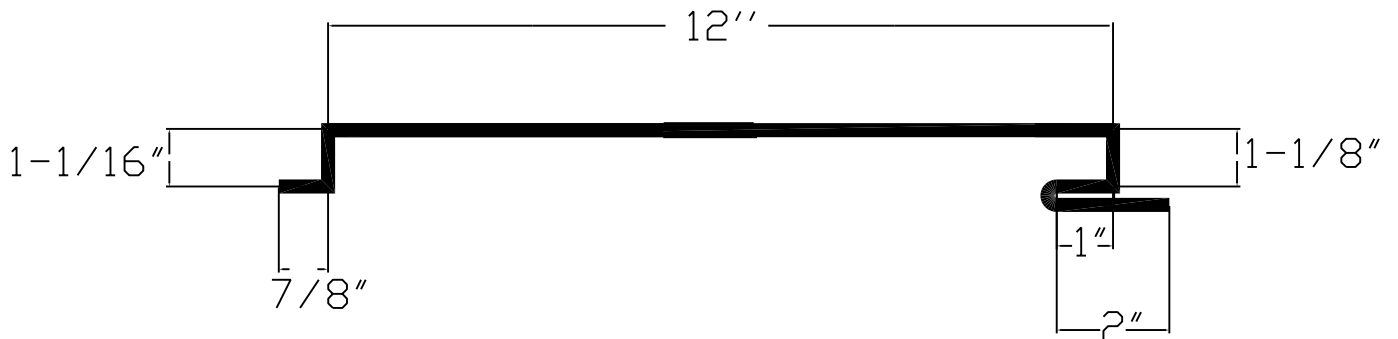
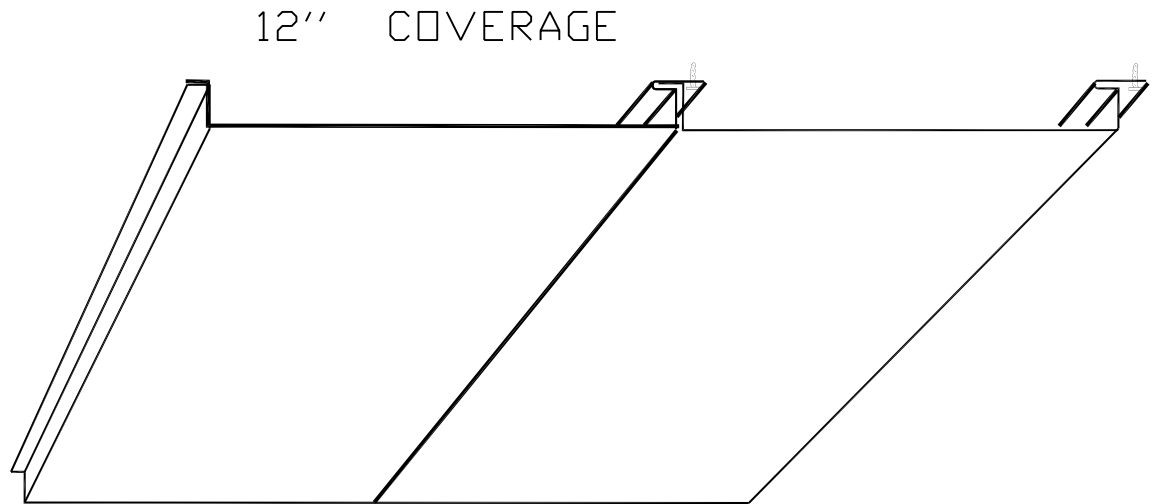

COASTAL METAL SERVICE

DIVISION OF BEACON SALES

1120 WEST CHESTNUT STREET
BROCKTON, MA 02301

PHONE: 1-866-792-8872
1-508-580-8436

FAX: 1-508-580-9704

STYLE "A" EAVE TRIM

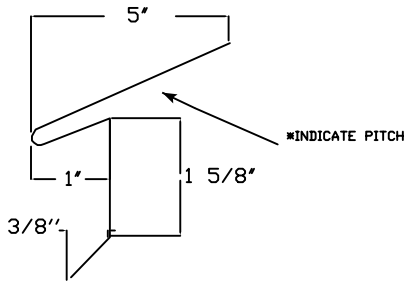

VALLEY

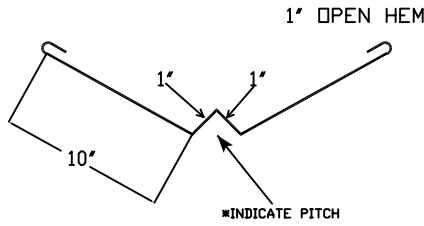

HIP AND RIDGE

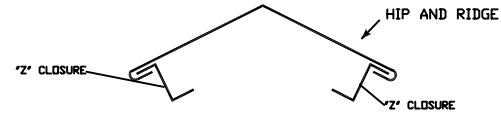

VENTED RIDGE CAP

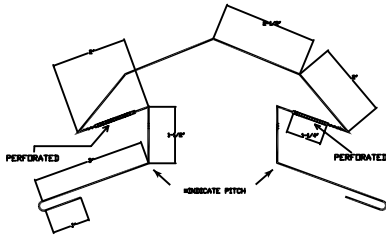

RAKE TRIM

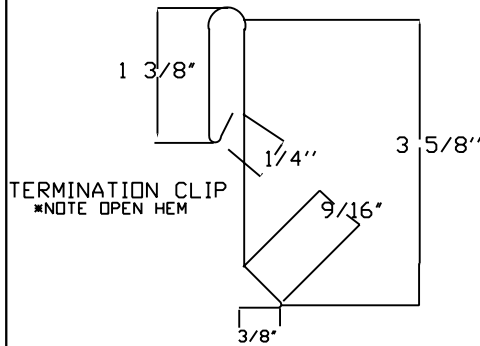

SIDEWALL

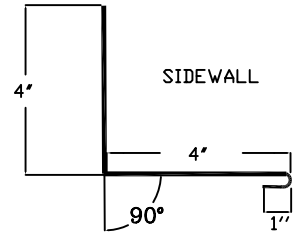

TRANSITION TRIM

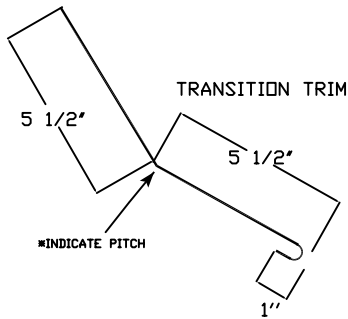

COPING CAP

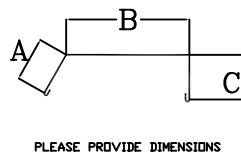

SOFFIT AND PERFORATED SOFFIT

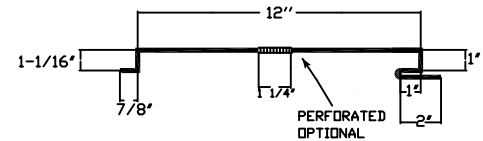

HEADWALL

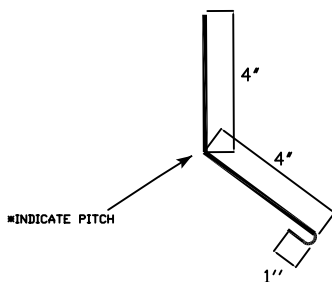

VERTICAL WALL PANEL

